

RÖSLER[®]
finding a better way ...

www.rosler.com

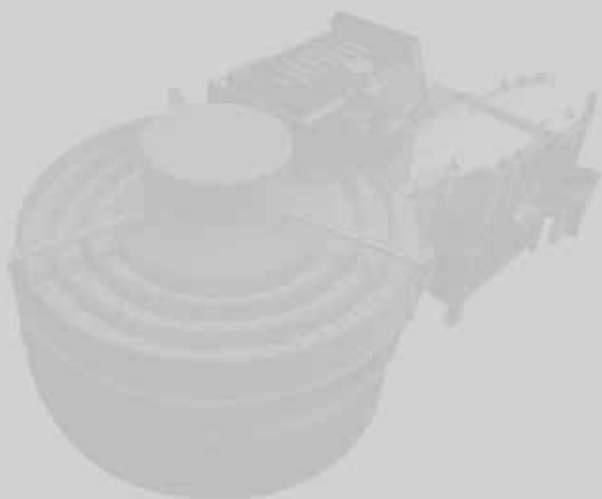

*Rotomatic continuous
flow systems*

The Rotomatic continuous flow system

First-class machining for your parts

The technique of continuous vibratory finishing is steadily gaining ground. Although different processes have varied costs, a simple calculation shows that shorter throughput times and pared-down part handling increase productivity and reduce labour costs while ensuring consistently high product quality. Rotomatic – the all-round cost saving solution!



A forward-looking partnership

At Rösler, we measure success in terms of customer benefits. It is this philosophy that has made the Rösler group the world's biggest and most efficient manufacturer of vibratory finishing systems. Our work practices are geared to our customers' wishes and technical requirements – not to rigidly standardised product specifications. This cooperative approach forms the basis for developing technical solutions which are tailored to the concrete production demands of each customer. Flexibility is our forte, making us a strong, reliable surface finishing partner for our customers both now and in future.

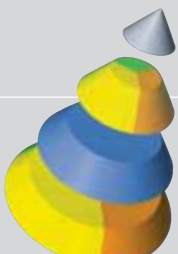
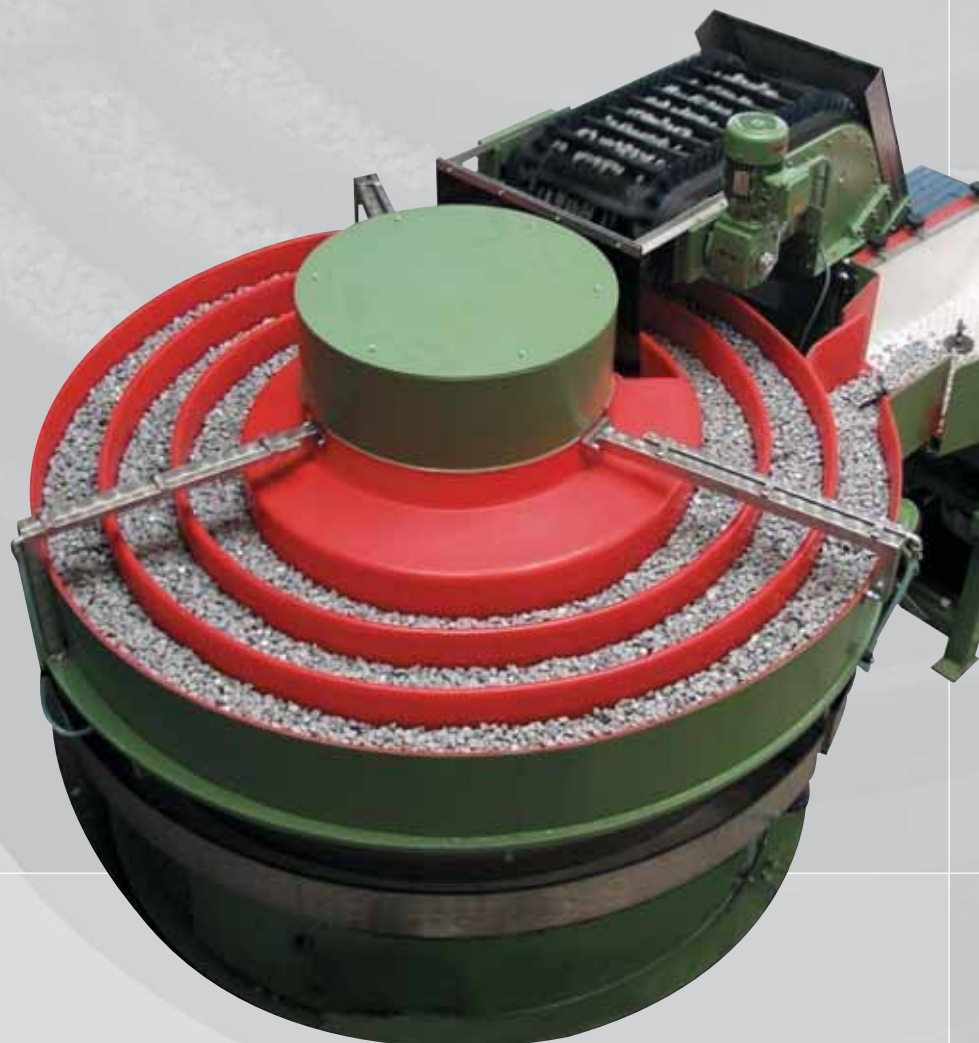



Processing media production

Rösler offers the most comprehensive range of processing media in the world. 50 years of development and production form a broad base for over 8,000 different compounds, ceramic and plastic abrasive media. These are available to customers throughout the world for all kinds of applications.



Areas of application ...

Deburring, grinding, rounding, polishing and peen-finishing of punched, cast, forged or machined parts using the power of the Rotomatic continuous flow system. The high throughput, huge economic efficiency and extensive automation potential of this technique is attracting growing numbers of users.

How it works ...

Continuously or cyclically loaded parts are circulated according to the vibratory finishing principle in a U-shaped process container filled with abrasive or polishing media. The machining parameters, such as throughput time and grinding or polishing finish can be adjusted at will via the variable unbalance and rotational speed settings. After passing through the machine once, the media and parts are separated in the subsequent separating station. At the same time, the parts can be rinsed off and transferred to the after-treatment station, while the media are returned to the machine for re-use via the combined vibratory/belt conveyor.

The Rotomatic System

First-class technology

The superior concept of the Rösler-ROTOMATIC CONTINUOUS FLOW SYSTEM is guaranteed by in-house development and production of all main components. The sophisticated machine structure, generous machine sizes, robust drive engineering, spacious separating stations and intelligent control technology ensure reliability even in tough working conditions.

1 Machine bowl

- ▶ Solid, torsionally rigid welded structure with special ribbing
- ▶ Stress-free annealed
- ▶ Process water exchange via large, easily exchangeable bottom drains distributed over the entire length of the machine
- ▶ Helical spring suspension
- ▶ Opening for changing the abrasive media
- ▶ Inspection hole with dome-shaped cover
- ▶ Wear-protection lining in special, highly abrasion-resistant polyurethane

2 Drive engineering

- ▶ Rösler direct-drive vibratory motor
- ▶ Adjustable unbalance weights
- ▶ Frequency converter, automatic speed control

3 Machine base frame

- ▶ Sturdy, stress-free annealed welded structure
- ▶ Inspection hole
- ▶ Feed ducts
- ▶ Vibration-absorbing machine feet

4 Large-surface screening machine

- ▶ Unbalance (and optionally) variable-speed twin vibratory drive
- ▶ Multi-stage separation screens with quick changeability
- ▶ Undersize screening facility with outside access
- ▶ Part rinsing device
- ▶ Optionally: magnetic part separation
- ▶ Optionally: reverse screening device

5 Media transport system

Universally adaptable for differently shaped abrasive media and production rates. Consisting of the following assemblies:

- ▶ Vibratory cross conveyor with adjustable flow rate in large-surface screening machine, with water drainage zone
- ▶ Z-shaped media return conveyor for low media transfer points, adjustable conveying speed
- ▶ Lifting station with extracting pump to remove contaminated process water

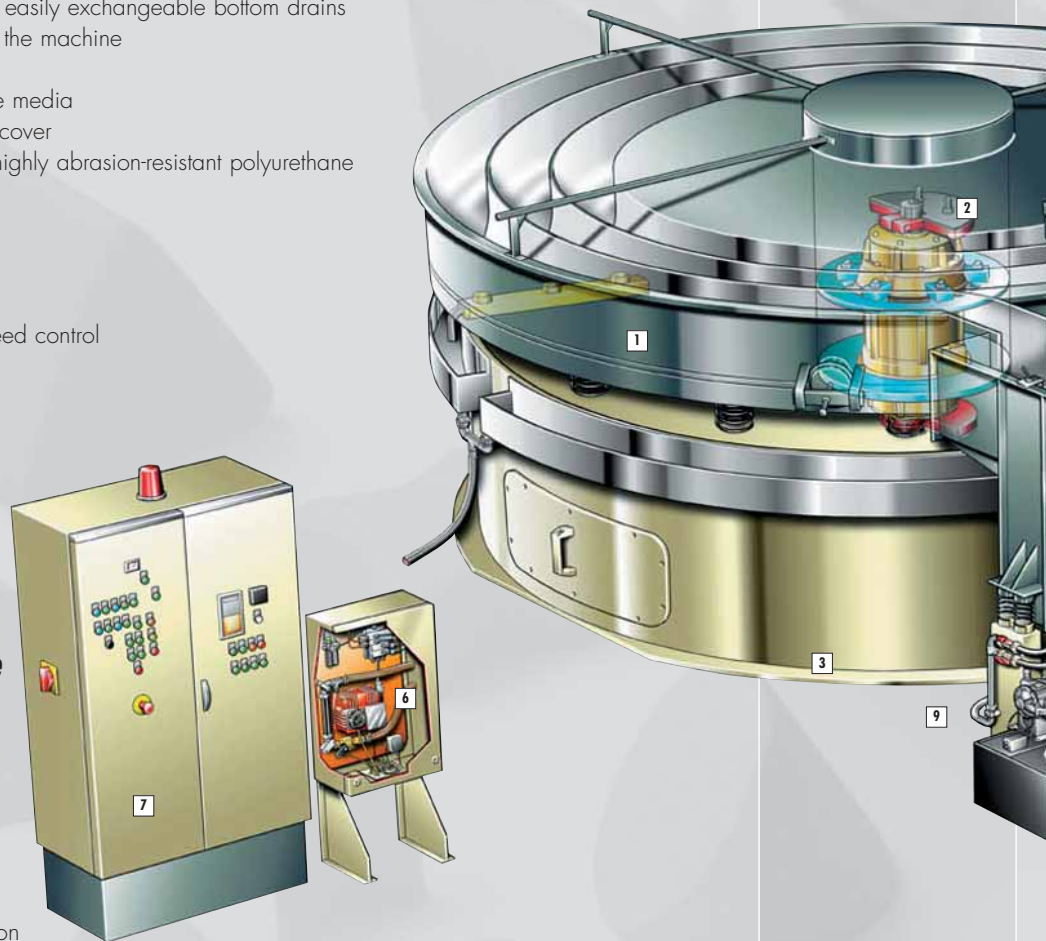



Produced with a top quality finish....

All Rösler installations are finished-wherever possible-with a high grade durable powder coating (an environmental-friendly produced product)

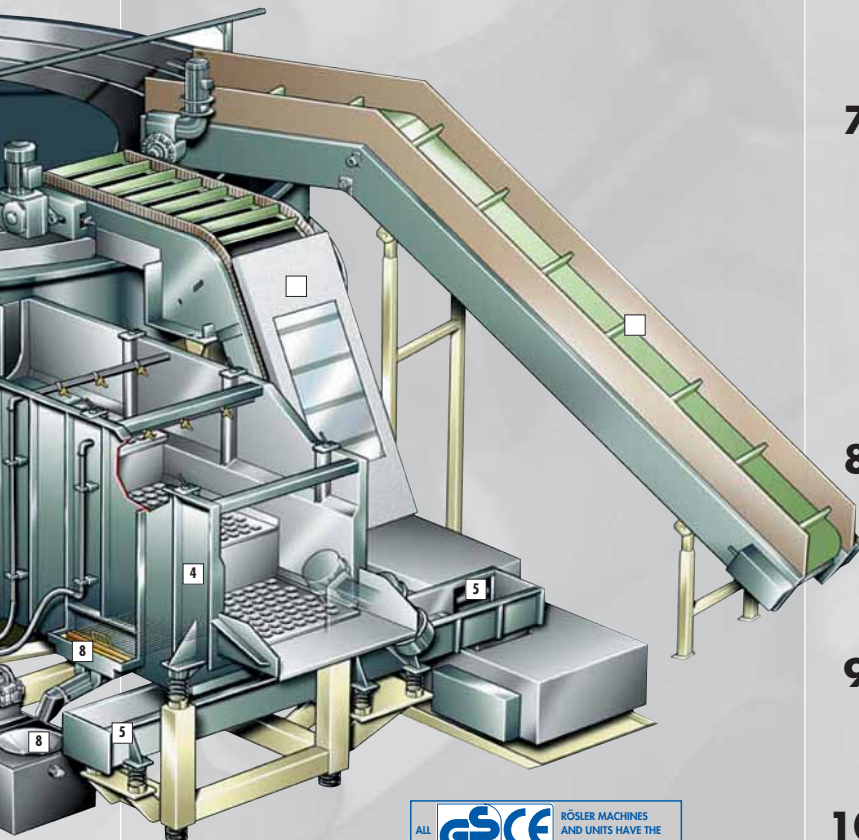

6 Process water control unit

- ▶ Central process water and compound distribution
- ▶ Control device for part rinsing in large-surface screening machine

7 User friendly central control panel

Fully automatic panel, controlled and monitored via PLC system.

- ▶ Multifunctional operating device with clear-text display
- ▶ Individual programming
- ▶ MPI interface link
- ▶ Optional: production and machine data transfer block (PDA,MDA)
- ▶ Teleservice package for accessing remote diagnostics

8 Undersize media separation unit

Permanent undersize screening of abrasive media

- ▶ Side inserted exchangeable screens, without use of tools
- ▶ Optional: pneumatically activated self-cleaning screen

9 Central lubrication system

- ▶ Demand-responsive, electronically controlled lubricant supply to main drive motor

10 Noise suppression cabin

- ▶ Optional extra (not shown)
Segmentally structured noise abatement cabin with access doors, windows, lighting and ventilating elements tailored to specific conditions on site

11 Part loading

- ▶ Conveyor belts, vibro-channels, handling robots etc. can be readily interlinked on an individual basis

User-friendly details, perfect result

The ROTOMATIC units are ultra-modern, universally applicable, spiral-type throughfeed systems for continuous part machining. The work bowl is of an optimal shape from the point of view of fluid and process technology. Variable channel widths with variable working lengths of up to 27 metres open up a whole range of applications.

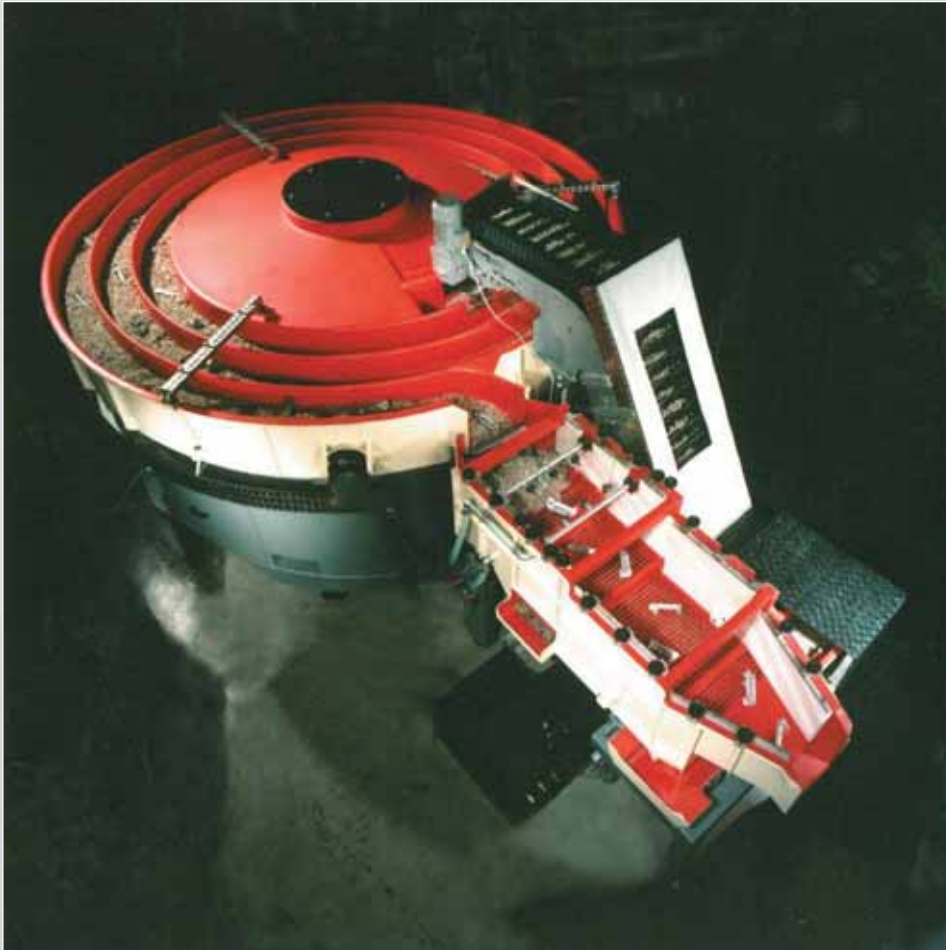

A marvel of technology ...

- ▶ The process container is specially designed to ensure consistent process results.
- ▶ Cyclically loading of sensitive parts can be readily carried out in a way that protects them from part on part contact
- ▶ Durable wear-resistant lining
Highly abrasion-resistant special polyurethane guarantees an extra-long service life even in extreme conditions.



Special drive technology ...

The direct-drive unbalance motor developed by Rösler[®] offers large power reserves. The tried-and-tested motor guarantees loss-free power transmission to the processing channel. Optimal access to the variable unbalance weights allows individual intensity adjustments. Additional flexibility is ensured by the continuous speed adjustment via frequency converters.



Work bowl with special motor

The difference in detail ...

Consistent process results thanks to evenly distributed process water supply. Easily exchangeable floor drains at the lowest point of the process container guarantee a continuous exchange of process water.



Process water distribution



Floor drains



Dirty water discharge channel

A strong foundation ...

- ▶ A solid welded structure is used for the machine base frame. This provides a base for the process container which vibrates freely on the helical springs.
- ▶ Large assembly holes facilitate unbalance adjustments and maintenance work.
- ▶ Vibration-absorbing elements minimise the transmission of vibrations at installation site.



Clean and reliable separation of high-quality parts

The trouble-free separation of abrasive media and parts has a decisive influence on the plant output and part quality. For this reason, our Rotomatic is equipped with a particularly large and technically elaborate separation system.

This ensures universal application and even greater efficiency.

Precise, flexible and fast ...

The separating station, which is independent of the process bowl, is driven via separate, adjustable vibratory motors. This guarantees optimal separation for any given application – without influencing the process intensity in continuous or cyclical production.

- ▶ Seamless inside wall coating with noise-absorbing, corrosion-resistant polyurethane
- ▶ Reversing stages with various standard heights for emptying media from bowl-type parts
- ▶ Quick-clamping screens exchangeable without tools allow flexible adaptation to any separation task
- ▶ The sensitivity of the parts determines the intensity and separating speed, which can be continuously adjusted.
- ▶ Integrated rinsing devices for cleaning the parts

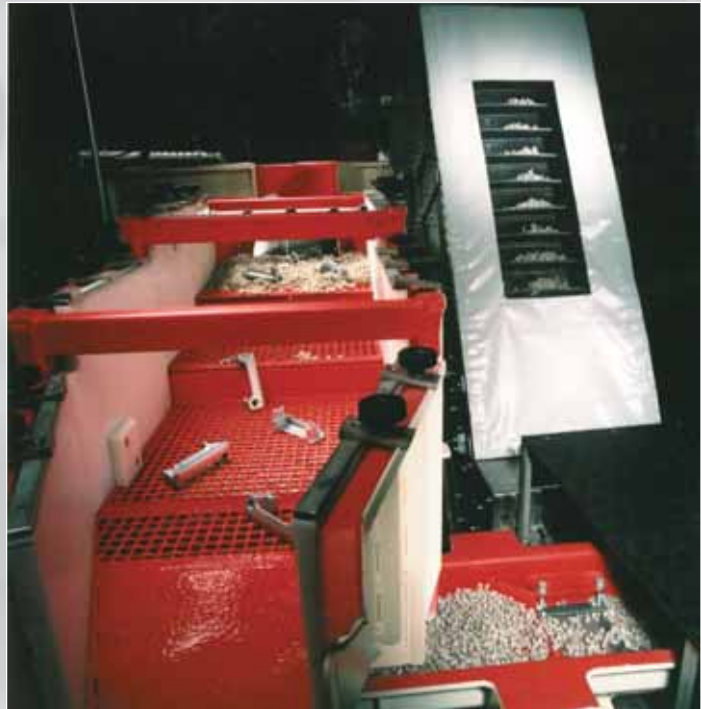

Öko-Plus cleaning system

Öko-Plus cleaning system ...

The Öko-Plus system allows the parts to be cleaned and the water simultaneously recycled. Spray nozzles above and below the sieve plane aim the water jet directly at the parts.

Impressive flexibility ...



Media conveyor system

An efficient media transport system provides the basis for a maximised plant output and customised applications. After the separation of media and parts in the large-surface screening machine, the media are transferred to the vibratory cross-conveyor. Effluent is removed above the exchange screen segment area. The linear and vertical transport is performed by a wide conveyor belt equipped with flexible edge cleats and drivers. Effluent collects over the entire surface of the drip pan is diverted away. All transfer points have minimised fall heights and are thus suitable for ceramic abrasive inserts!



Lower cross-conveyor channel with residual water screen segment and media conveyor belt

Rigorous magnetic part separation ...

For the separation of ferromagnetic parts identical or smaller in size to the media, the Rotomatic is equipped with one or two drum-type magnetic separators or a belt-type magnetic separator.

Individual operation:

Efficient drum-type magnetic unit with strong magnetic force, height-adjustable, speed-regulated, to minimise loss of abrasive media.

Tandem operation:

Offers twice the reliability.

Demagnetisation:

The optionally available, patented demagnetiser installed in the drum body facilitates the positioned deposition of the part while simultaneously demagnetising it.



Magnetic part separation



Variable part shapes ...

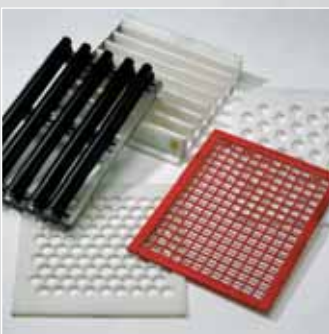

Separation Screens

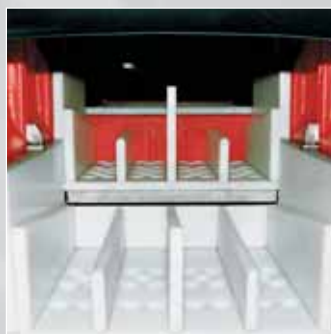

Reversing stage separation with special screen for complex part shapes

Different parts call for adaptable separation screens

Easy care and high availability

You can rely on Rösler's® fully automatic Rotomatic systems!
They offer maximum performance and availability combined with minimum wear and maintenance costs.
And if you do encounter any problems, our mobile, qualified full-time service team offers a comprehensive spare part service any time, anywhere.

A pleasant working atmosphere ...

On request, we can supply soundproof cabins specially adapted to the conditions on site



Learning from experience ...

A laterally inserted fines screen reliably separates undersized matter which can get stuck in the parts. Optimal access and the self-cleaning design help reduce cleaning times to a minimum.

Abrasive media fines separation with collecting zone



Shorter setup times ...

A well positioned discharge hole is provided for emptying the abrasive medium.



Changing the abrasive media

Made-to-measure maintenance ...

Demand-based lubrication of the motor bearing, controlled via the PLC maintenance program.



Central lubrication system with progressive distribution

Intelligent control system – all systems go

The programmable controller links together the entire system. Current production data, functions and times can be conveniently displayed and altered at the digital operator panel.

Programmable electronics ...

Programmable electronics are the basis of modern control engineering. Interlinked systems with loading and after-treatment units can be directly programmed and monitored via PLC technology. All the main protection and control functions are monitored, e.g.

- ▶ Media return transport
- ▶ Water and compound supply
- ▶ Dry running
- ▶ Service data
- ▶ Rinsing device
- ▶ Part loading: transfer and after-treatment units



Control systems for all requirements



Down to the last detail ...

The pilot valves for process water, rinsing and cleaning devices, volume indicators for water and compound supply system are all clearly organised for optimal user-friendliness.

Pneumatic and process water distribution

ROTOMATIC with internal separation ***– space-saving in online operation***

Rotomatic systems with internal separation offer compact dimensions with no loss of performance. The principle of maximum throughput coupled with minimum space requirements has been consistently applied in this series.

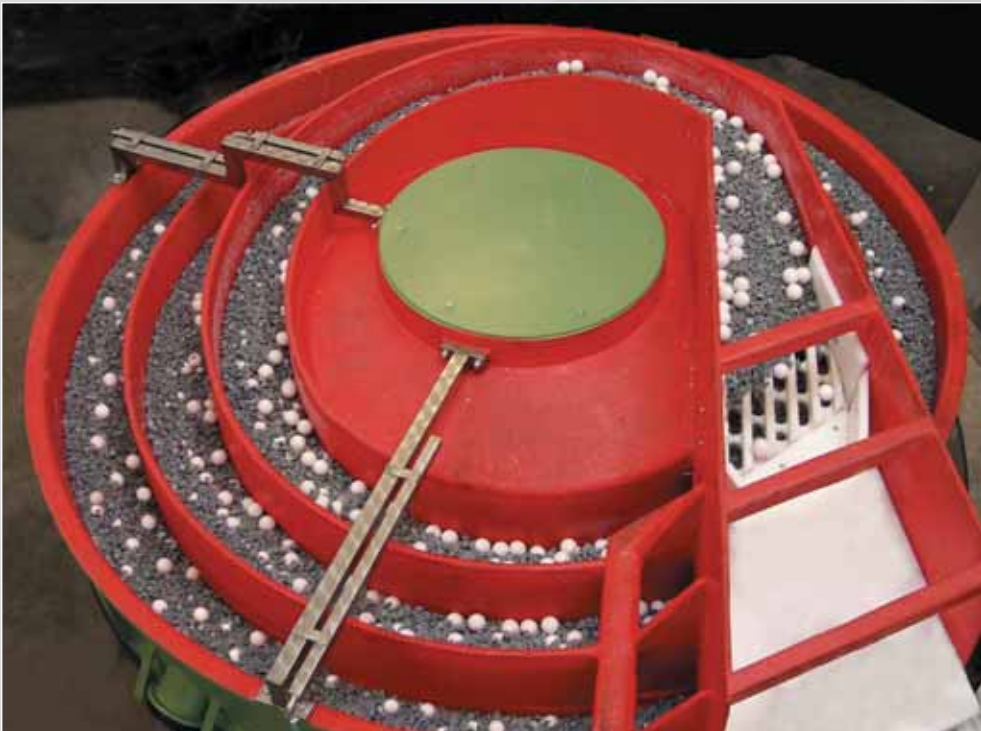

ROTOMATIC R 200/18 SI

What's new ...

Vibratory finishing is often tacked on directly to production systems such as presses, saws, etc., where the available space is usually very limited.

In this series, however, the separating zone is directly integrated in the work bowl, thus saving space and money.

Technical details ...

- ▶ Work bowl: 200 mm
- ▶ Length: 18 m
- ▶ Integrated separation zone with exchangeable sieve planes
- ▶ Part rinsing device in the separation zone
- ▶ Continuous speed adjustment of main drive
- ▶ Integrated facility for separating undersized matter from abrasive media

XXL machining output - the ROTOMATIC R 370/12 SE

Even large-volume parts are suitable for ROTOMATIC machining.

The system's unbeatable throughput depends on the generous length and width of the process container.

Applications range from die-cast aluminium housings through machined hydraulic housings to punched parts.

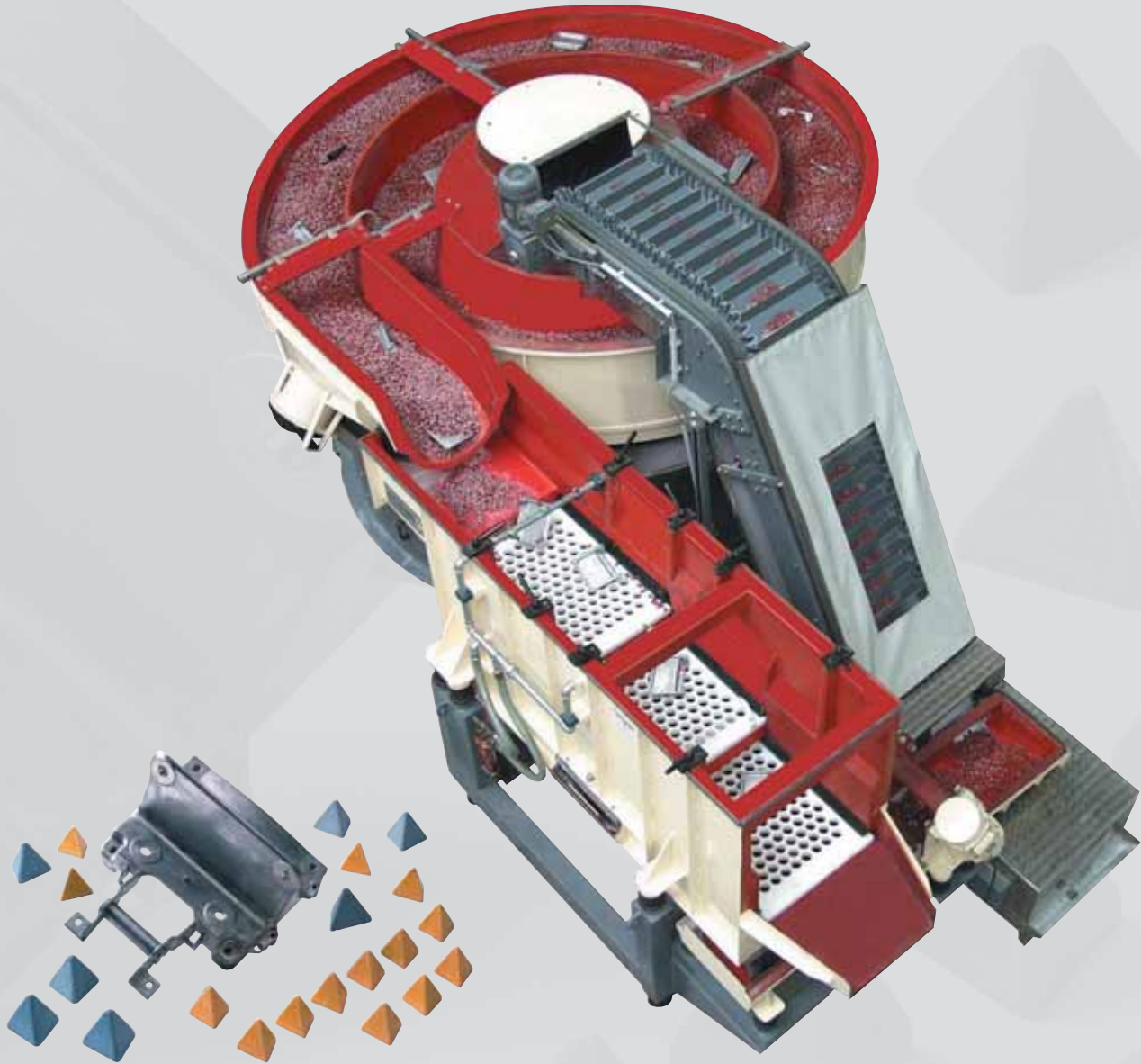

Technical details ...

- ▶ Effective work bowl: 370 mm
- ▶ Length: 12 m
- ▶ Large-surface screening machine with multi-stage separation screens (reversing stage height: 200 mm)
- ▶ Integrated facility for separating undersized matter from abrasive media
- ▶ Suitable for parts up to approx. 350 mm x 350 mm x 350 mm (l x w x h)
- ▶ Continuous speed adjustment of main drive

Planning the future – high-performance series production

Rotomatic technology stands for automation at the highest level.
In other words: a complete, efficient vibratory finishing facility for modern just-in-time production

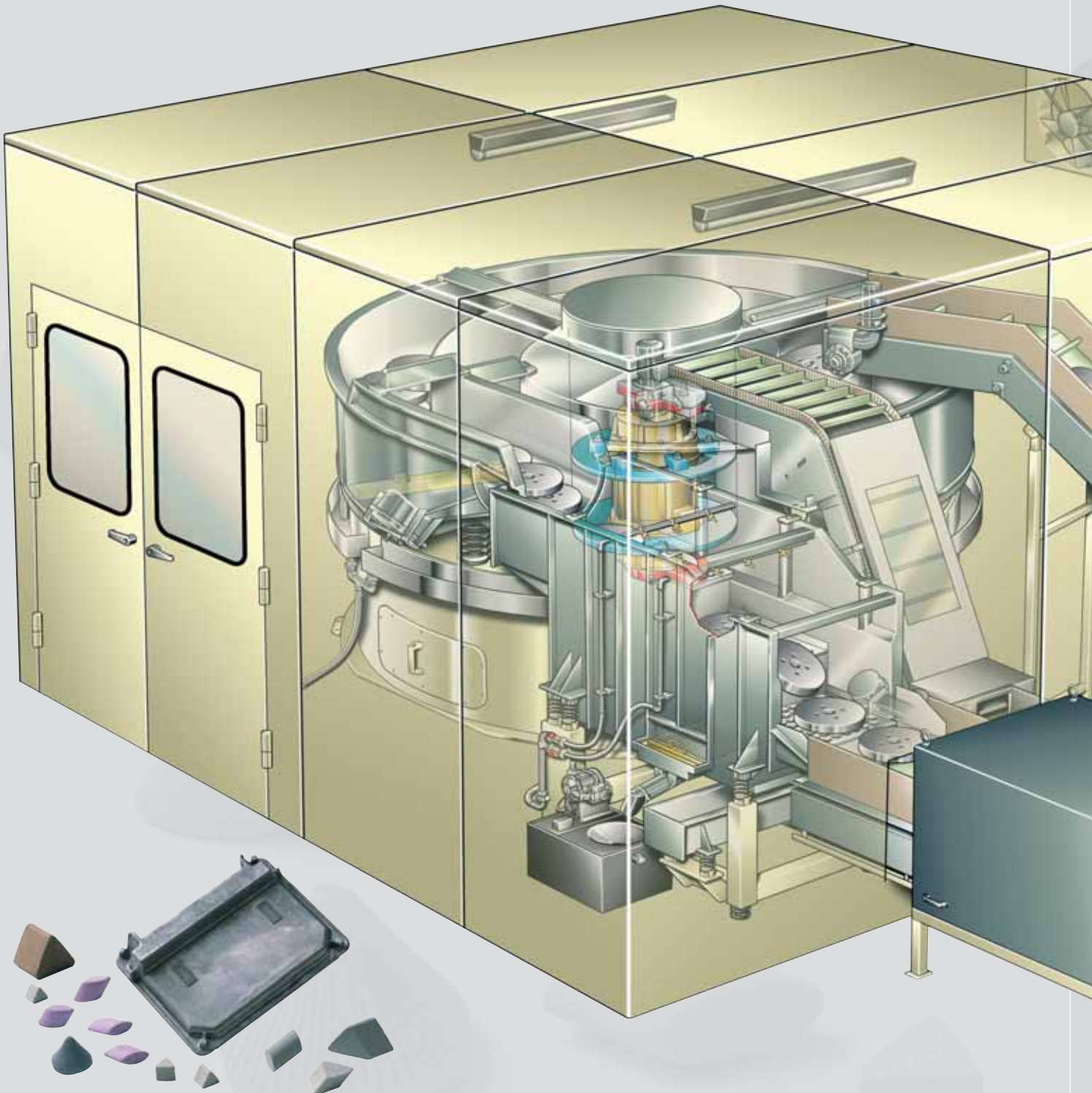

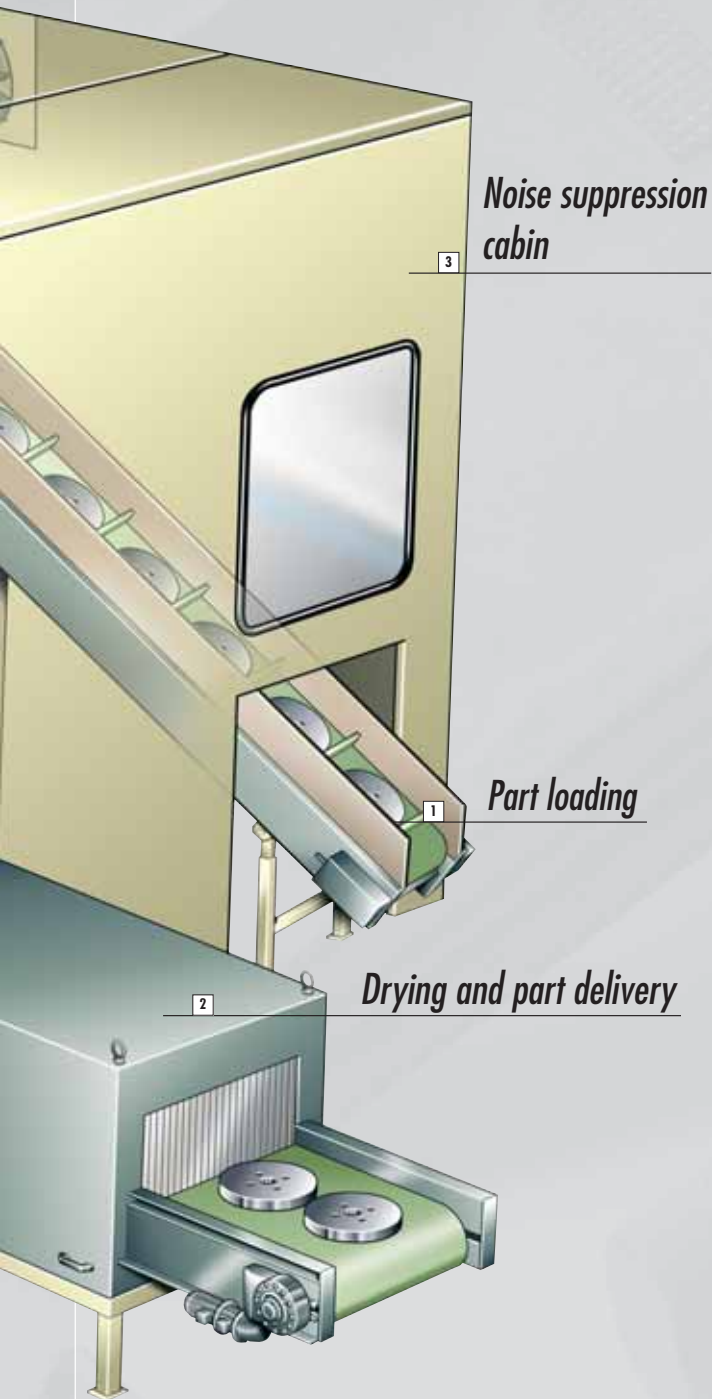

Rotomatic R 210/27 SE
Part loading conveyor
Vibratory round drier



Rotomatic R 370/12 SE in linear arrangement with loading conveyor for unmachined parts, vibratory washing unit and hot-air drying conveyor.

Customised plant engineering – using our creativity and experience to solve your problems

Whether operated online or as an independent machining centre, the Rotomatic comes into its own when the part supply and after-treatment units are directly linked to the basic unit. Two fully equipped interlinking areas allow any plant combination.

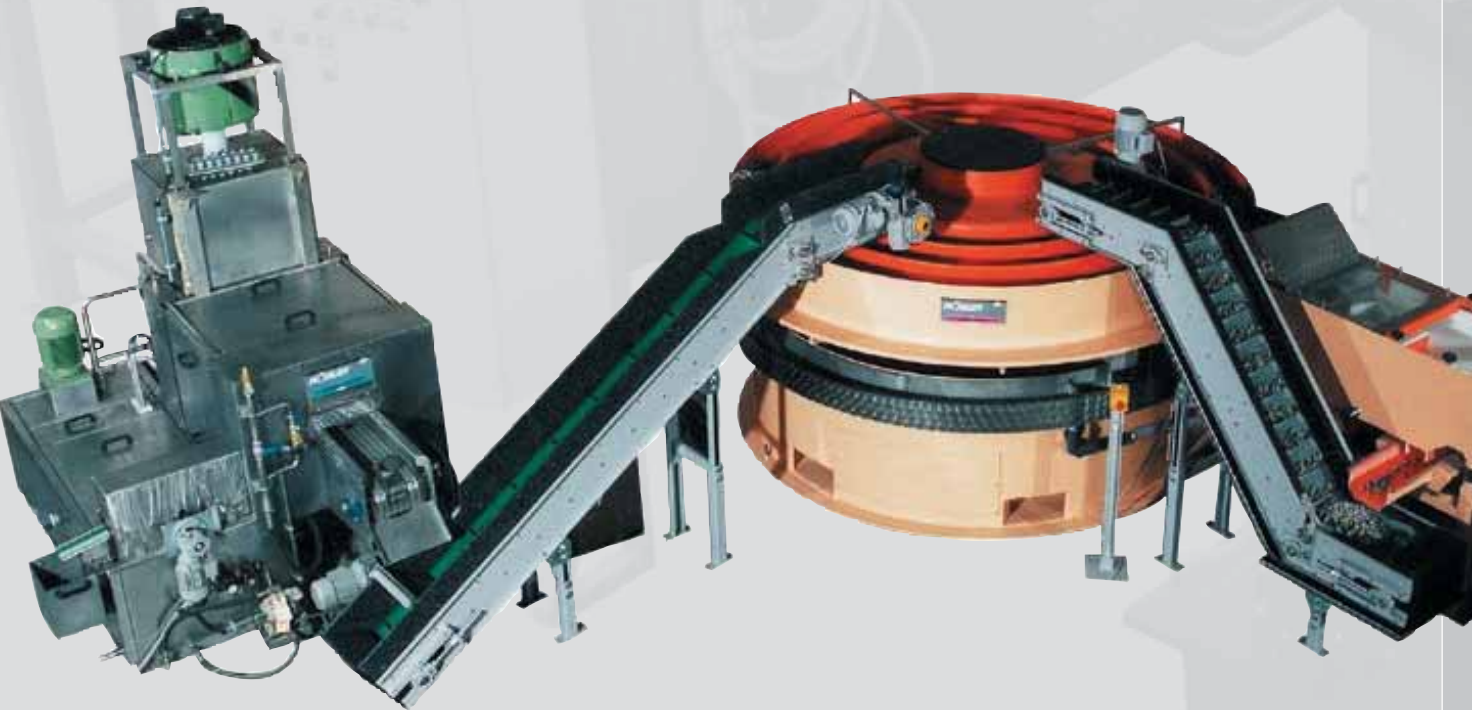

Rösler belt washer interlinked with Rotomatic and finished part storage table

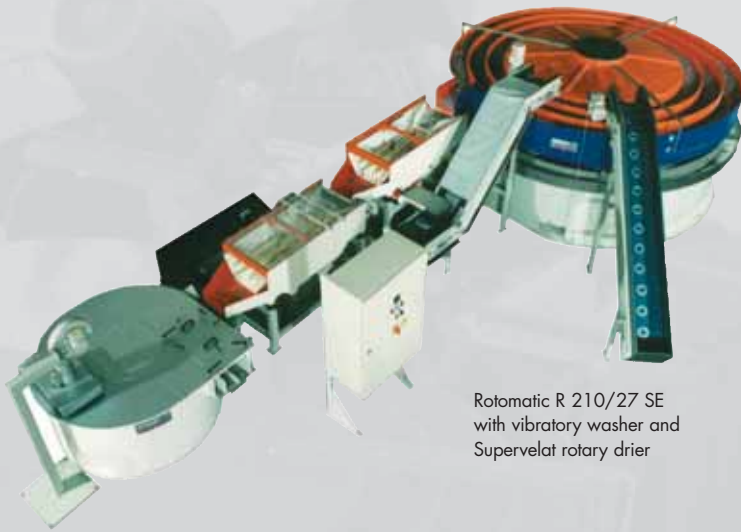

Rotomatic R 210/27 SE
with vibratory washer and
Supervelat rotary drier



Rotomatic system with part cleaning,
drier and process water recycling unit

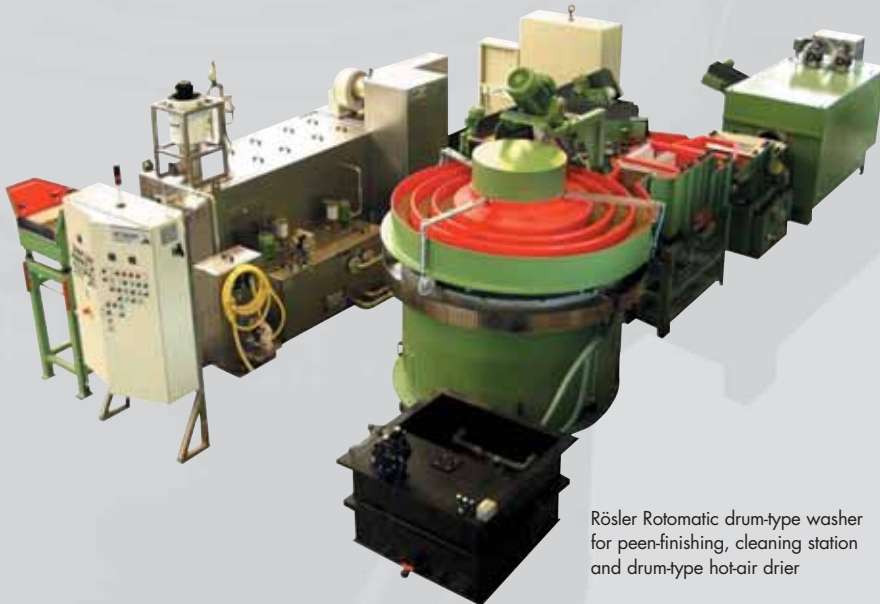

Rösler Rotomatic drum-type washer
for peen-finishing, cleaning station
and drum-type hot-air drier



Loading conveyor, Rotomatic R 370/12 SE, belt-type hot-air drier, rotary storage table

Big on performance – small on space

The Rotomatic range from Rösler comprises a variety of work bowl widths and lengths. For large-volume parts, we recommend Type R 370/12 SE. Especially compact is the SI type machine with internal separation zone. With this product range, we are able to offer our customers the right solution for every situation!

Come and judge the performance of our machines for yourself at the numerous test centres, at our head office, or branches.

Our range of systems

Technical data – Rotomatic

Type	SE					SI
	R 150/15 SE	R 200/18 SE	R 210/27 SE	R 280/24 SE	R 370/12 SE	R 200/18 SI
Developed length of process (m)	15	18	27	24	12	18
A (mm)	4000	5100	5800	5500	5100	3100
B (mm)	2600	2800	3600	3700	3500	2800
C (mm)	2000	2250	2250	2300	2250	1660
D (mm)	150	200	210	280	370	200
E (mm)	230	280	240	320	420	280
F (mm)	860	860	860	860	860	1360
G (mm)	500	500	500	500	500	500
H (mm)	1400	1600	1600	1650	1600	1430
I (mm)	approx. 850	approx. 850	approx. 850	approx. 850	approx. 850	approx. 850
Total output (KW) Total nominal output of motors	12	17	17	17	17	12
Main drive (KW) Nominal output of motor	7,5	12	12	12	12	12

effective: 05/03



Rotomatic series SE

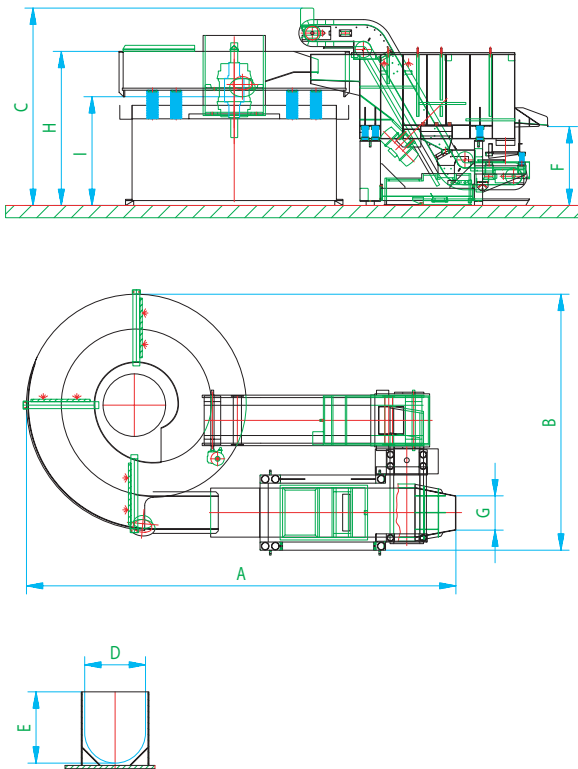

Rotomatic series SI

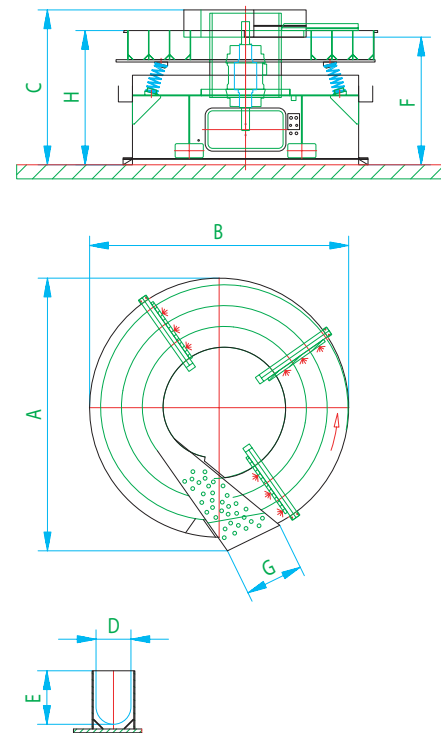

Our duty to the environment

Active environmental protection is an integral part of our company policy.

We use natural substances and recycled products in our production; similarly, long maintenance intervals, the repair and service-friendly nature of our machines and systems and the use of high-yield compounds (chemicals) and wear-resistant abrasive media save valuable resources, thus contributing significantly to the protection of our environment. The avoidance of pollution and waste and the return of packaging and recyclable materials are also given a high priority in production and sales.

This is documented not least by the following certificates:

- Water technology specialist
- Certified material recycler



Quality made in Germany

To us, quality means more than just reliability, durability and the absence of faults. At Rösler, quality is an essential part of our philosophy, and is expressed through the personal reliability and sense of responsibility of each member of staff. These efforts are reflected by various awards and the DIN EN ISO 9001 quality management certificate issued to all our areas of production.





D RÖSLER Oberflächentechnik GmbH · Werk Memmelsdorf
Vorstadt 1 · D-96190 Untermerzbach
Tel.: +49/9533/924-0 · Fax: +49/9533/924-300 · info@rosler.com

RÖSLER Oberflächentechnik GmbH · Werk Hausen
Hausen 1 · D-96231 Bad Staffelstein
Tel.: +49/9533/924-0 · Fax: +49/9533/924-300 · info@rosler.com

GB RÖSLER UK
Unity Grove, School Lane · Knowsley Business Park · GB-Prescot, Merseyside L34 9GT
Tel.: +44/151/4820444 · Fax: +44/151/4824400 · rosler@rosleruk.com

F RÖSLER France
Z.I. de la Fontaine d'Azon · B.P. 513 – St. Clément · F-89105 Sens Cedex
Tel.: +33/3/86647979 · Fax: +33/3/86655194 · rosler@rosler.fr

E RÖSLER International GmbH & Co. KG
Sucursal en España · Polg. Ind. Cova Solera C/Roma, 7 · E-08191 Rubí (Barcelona)
Tel.: +34/93/5885585 · Fax: +34/93/5883209 · rosler@rosler.es

I RÖSLER Italiana S.R.L.
Via E. Vittorini 10/12 · I-20049 Concorezzo (MI)
Tel.: +39/039/611521 · Fax: +39/039/6115232 · info@rosler.it

NL RÖSLER Benelux B.V.
Reggestraat 18 · NL-5347 JG Oss · Postbus 829 · NL-5340 AV Oss
Tel.: +31/412/646600 · Fax: +31/412/646046 · info@rosler-benelux.nl

B RÖSLER Benelux B.V.
Avenue de Ramelot 6 · Zoning Industriel · B-1480 Tubize (Saintes)
Tel.: +32/2/3610200 · Fax: +32/2/3612831 · info@rosler-benelux.be

A RÖSLER Oberflächentechnik GmbH
Hetmanekgasse 15 · A-1230 Wien
Tel.: +43/1/6985180-0 · Fax: +43/1/6985182 · office@rosler.at

CH RÖSLER Schweiz AG
Staffelbachstraße 189 · Postfach 81 · CH-5054 Kirchleerau
Tel.: +41/62/7385500 · Fax: +41/62/7385580 · info@rosler.ch

USA RÖSLER Metal Finishing USA L.L.C.
1551 Denso Road · USA-Battle Creek · MI 49015
Tel.: +1/269/4413000 · Fax: +1/269/4413001 · info@rosler.us

BR RÖSLER do Brasil LTDA
Estrada dos Galdinos 35 · Jd. Barbacena · 06700-000 · Cotia · São Paulo · Brasil
Tel.: +55/11/46123844 · Fax: +55/11/46123845 · rosler@rosler.com.br

ZA RÖSLER S.A. Surface Technologies
P.O. Box 7949 · 66 Regency Drive · Route 21 Corporate Park · Irene Ext. 31 · 0046 Centurion
Tel.: +27/12/345 2215 · Fax: +27/12/345 3731 · johanv@roslersa.co.za

CN RÖSLER – BEIJING
Office 11N, Tower A, Beijing Fu Hua Mansion · No. 8, Chaoyangmen North Avenue
Dong Cheng District · Beijing 100027 P.R. China
Tel.: +86/10/6554 73 86 · +86/10/6554 73 89 · Fax: +86/10/6554 73 87 · info@rosler.com.cn

- and more than 60 representations worldwide

